



Floveyor
Pty Ltd



D

J
K

E



**AERO MECHANICAL
CONVEYOR**

Introduction

The **FLOVEYOR** was invented in 1960, as an economical way to move peanuts. It is now used in over 30 countries to move most kinds of powders and granules - from cocoa beans to tea leaves. It is used in major industries, such as bottling, chemical, food processing and pharmaceutical, to move millions of tonnes of product per year.

The **FLOVEYOR** is inexpensive to operate, has a long life, uses a simple but unique principle and there is very little degradation of the product it moves.



What the FLOVEYOR does

The **FLOVEYOR** moves powders and granules by injecting them into a tube where there's a moving airstream. The material is fluidised and it is moved efficiently.

The power source can be:

- electric
- petrol
- diesel
- pneumatic
- hydraulic

□ **FLOVEYOR** mobile units come in three styles to suit all **FLOVEYOR** sizes. All **FLOVEYOR** mobile units are modular in design allowing flexibility for future requirements.

- M1 — Slimline design used for short, vertical applications.
- M2 — Extended base with supporting legs for longer **FLOVEYOR**s at any angle.
- M3 — Same as M2 with a winch for discharge height adjustment

F3 Stainless Steel

Accessories -

- **Standard Base**
- **B-type hopper**
- **Pneumatic sliding baffle**
- **120 discharge chute**
- **M2 mobile attachment**



Why it's better than other ways to move powders and granules

- Combine standard modules to build complex, integrated units
- Quick recovery of capital cost
- Can be controlled remotely
- Joins to existing equipment
- Handles fragile materials
- Low power requirement
- Works at any angle
- Low maintenance
- Small footprint
- Simple to clean
- Cuts waste
- Long life
- No dust

- FLOVEYOR screwfeeders are ideal for feeding materials that tend to 'bridge' or need to be control-fed into a FLOVEYOR.

FLOVEYOR screwfeeders come in three standard styles to suit capacity and discharge method FLOVEYOR screwfeeders are powered separately, but share FLOVEYOR construction and inlet accessories and can be supplied with supports for handling "bulk bag" and FIBC containers.



F3 Stainless Steel Accessories -
 • **Standard Base**
 • **120 discharge Mini Screwfeeder**



- FLOVEYOR rope assemblies are available with moulded Polyurethane (PU*) or riveted Polypropylene or PU discs fitted on galvanised or T304 stainless steel cable with T316 stainless steel as an option.

*(FDA, USDA and EC approved material)

FLOVEYOR moulded discs are uniquely moulded directly onto the cable, therefore reducing the likelihood of product contamination.

FLOVEYOR moulded disc technology delivers Polyurethane discs with superior strength, wear and heat resistance, as well as low maintenance.

How it works

- ❑ Electric motor - ranges from 360W to 7.5 kW
- ❑ The speed of the wire-rope assembly is about one quarter of the air speed in pneumatic systems, but very much faster than the speed of most mechanical handling equipment
- ❑ Aerated material. The degree of aeration depends on the material. Flour for example, aerates more than wheat. Flour has a compacted density of 560 to 640kg/m³ and an aerated density of only 130 to 160kg/m³. Wheat has a compacted density of 720 to 770 kg/m³ and a density in the moving **FLOVEYOR** of 560 to 610kg/m³. So the throughput of aerated flour in an F3 **FLOVEYOR** (for example) is 5.5 tons/hr - much less than aerated wheat at 30 tons/hr.

- ❑ Material is fed into the slow moving centre of the sprocket. It accelerates and moves to the outside by centrifugal force.
- ❑ The wire-rope assembly drives the air around in the tubes. The moving air then moves the material. The plastic discs fit loosely in the tubes and housings. They move fast and can fluidise a surprisingly wide range of materials.
- ❑ Drive position can be at the top or bottom for short/medium units and top only for longer and drag units.
- ❑ **FLOVEYOR** Drag Units are slow speed machines that incorporate multiple inlets and/or outlets, placed in variable positions with a choice of control type. **FLOVEYOR** Drag Units are customised to suit individual applications and product type. They can be used in conjunction with standard **FLOVEYOR** units to provide the total material distribution solution.

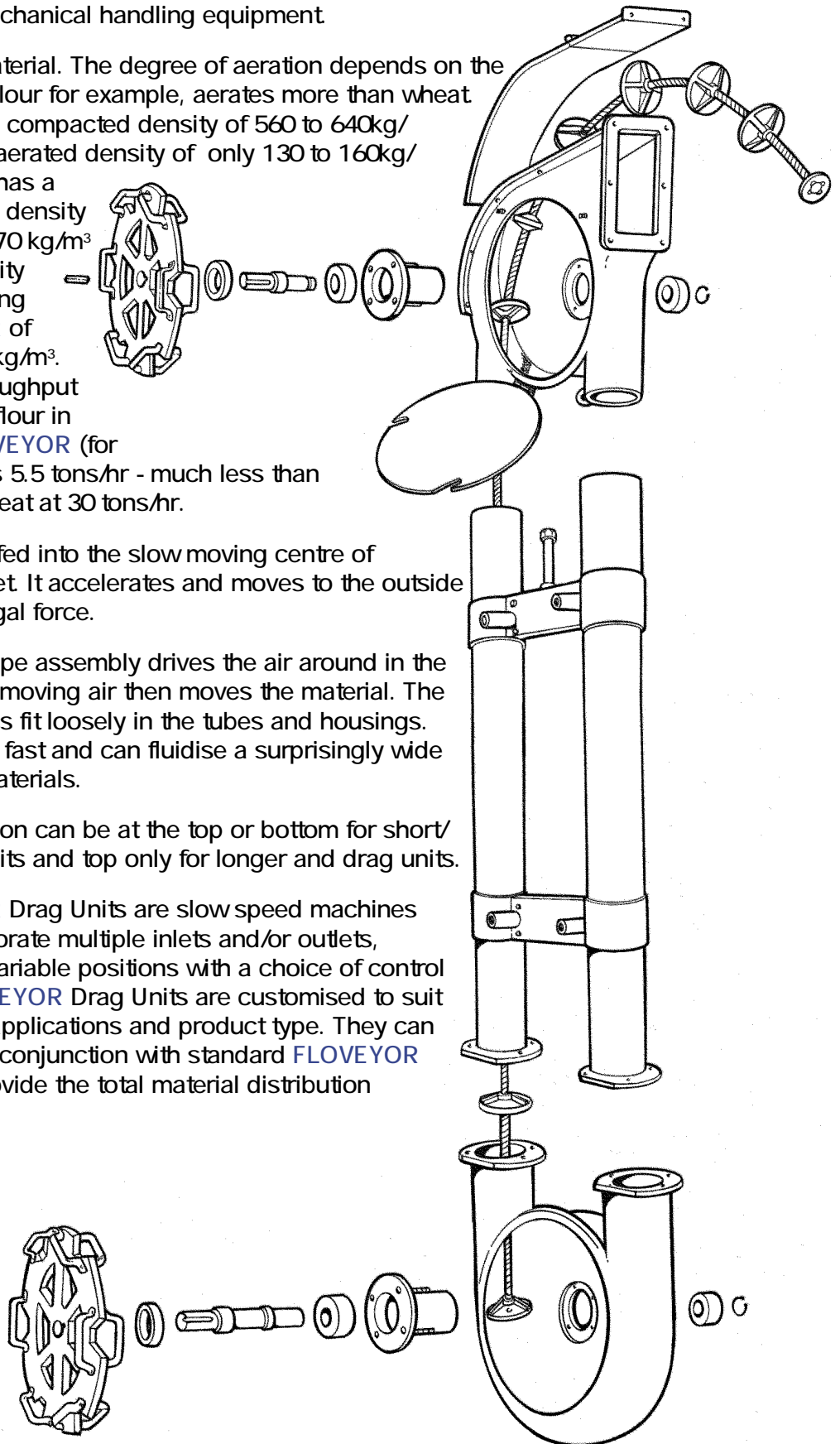

The **FLOVEYOR** was invented by Robert Walker, a Perth consulting engineer. In the late 1950s he was called in to help design a factory and needed an inexpensive conveyor for peanuts. He couldn't find anything suitable on the market, so he set about devising a simple system himself. He made a prototype machine by gluing wooden discs onto a wire rope. It worked even better than he'd hoped. It had the marks of all good inventions: it was simple and solved a down-to-earth problem (transporting a difficult material).



He took out a patent, modified the design for powders and set up a trading company in partnership with his wife. The **FLOVEYOR** was first shown publicly at the Perth Royal Agriculture Show in 1961. Orders started to come in from farmers, where word soon got around that it was ideal for handling grains.

In 1964, the partnership was changed to an incorporated company: Production Machinery Co. Pty Ltd. Then in 2005, a new company **FLOVEYOR PTY LTD**, was created.

The company has seen an impressive growth over forty years. **FLOVEYORs** are now sold worldwide through a network of distributors.

*The graph demonstrates the throughput in tonnes/hour for product handled by the range of **FLOVEYORs**. Note that the throughput varies with the product*

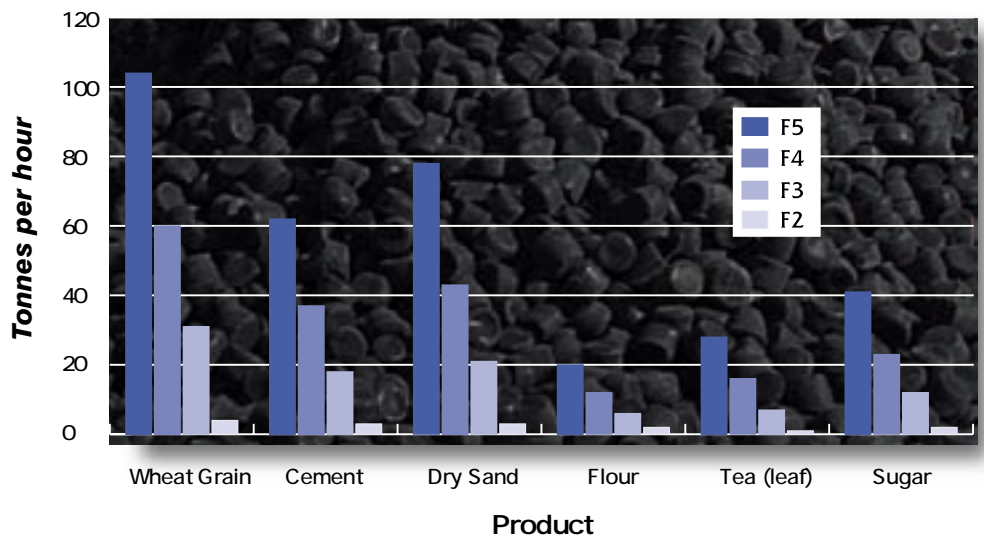

Ordering



Your **FLOVEYOR** Distributor will help you choose a unit (or units) and build them into a system that suits your needs. You may be best served by coupling several machines as an integrated solution to your material handling. There is a variety of accessories including inlets and discharges available.

Your Distributor can also demonstrate how your material will work in the machine and can make sure it will convey satisfactorily.

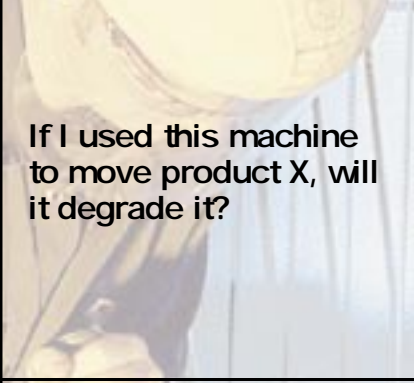
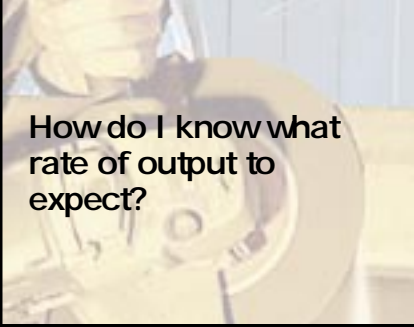
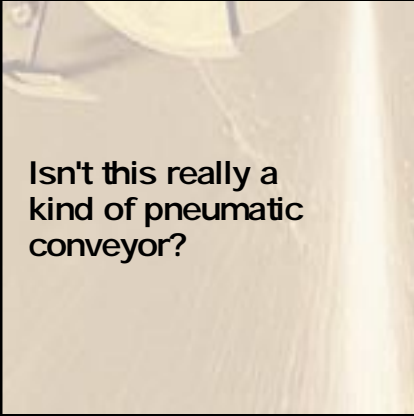
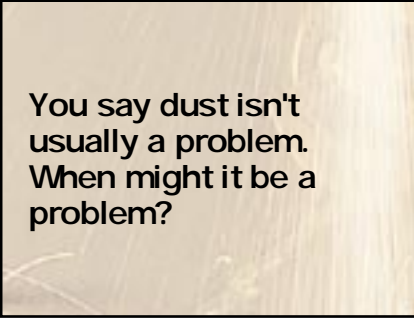
Frequently asked questions

 <p>How long does a FLOVEYOR last?</p>	<p>It depends what material you're putting through it. With a soft material like flour, there's little wear and the machines can run for decades with only minor maintenance. Some machines have been running more than 25 years. An abrasive material will mean more frequent replacement of the wearing parts.</p>
 <p>If I used this machine to move product X, will it degrade it?</p>	<p>In almost every case, we can say: no, degradation is minimal - no matter what X is. With something delicate like tea leaves, which is less and less valuable the more the leaves are broken, there's so little breakage that FLOVEYORs are regularly used to transport tea leaves in large quantity.</p>
 <p>How do I know what rate of output to expect?</p>	<p>It would probably be impossible for you to estimate. The output depends on the physical properties of the material. We've gathered much experience and have rules of thumb for almost any kind of material.</p>
 <p>Isn't this really a kind of pneumatic conveyor?</p>	<p>No. It relies on a different principle. A pneumatic conveyor needs a lot of pressurised air blown through it. So there's usually a great deal of dust at the outlet. With the FLOVEYOR, the air movement is in the opposite direction, hence a cyclone is not required to separate the air from the product. The work is done by the plastic discs: they push on the air, which in turn moves the product.</p>
 <p>You say dust isn't usually a problem. When might it be a problem?</p>	<p>When the FLOVEYOR is being fed by bags and the inlet hopper is open, if dust is generated, you can fit a dust hood to the hopper. That always solves the problem. Or the hopper can be loaded inside a sealed and ventilated chamber.</p>

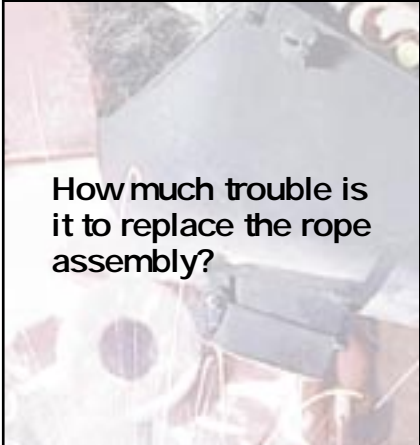
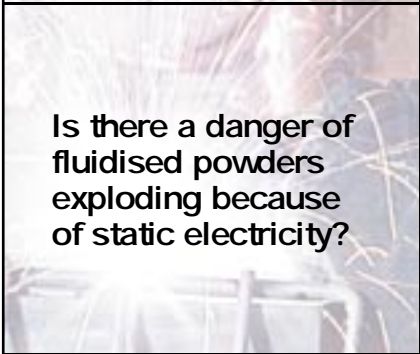
Frequently asked questions

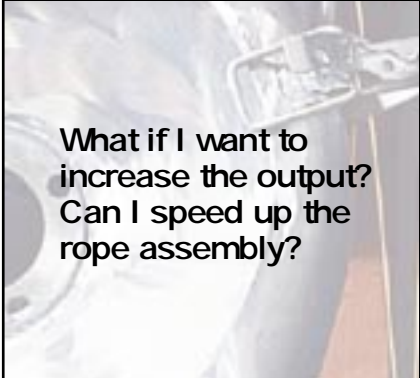
 <p>How easy is the machine to clean?</p>	<p>It depends what you're putting through it. In most cases, the machine is self-cleaning. It will usually empty itself of materials that have a low-to-medium density. If cleaning is needed, this really is an easy machine to clean. You don't have to take it apart to clean it. Whilst running the machine, residue material can be blown through with compressed air, or water can be run through it, then drained out.</p>
 <p>How much trouble is it to replace the rope assembly?</p>	<p>The machine was designed to make this job easy. You first open the hinged top cover. That gives you access to the rope assembly. Then find the coloured joining disc, undo the four bolts, attach the new rope assembly to the old one. Use that to pull the new assembly through, detach the old one and join up the ends of the new one after knocking the housing back down a little. It's all done with minimum downtime. Then you re-tension the new rope assembly.</p>
 <p>Is there a danger of fluidised powders exploding because of static electricity?</p>	<p>We have never known it to happen. First, there's only a small volume inside the tube (unlike a large shed filled with flour dust). So the explosive volume is very small. Second, the casing is metal and you can easily conduct away any static. We recommend you earth the casing if you're using explosive materials.</p>
 <p>Is there anything it won't move?</p>	<p>Yes. Things like stones, nuts and bolts and anything else that's very dense and hard or large particles beyond the size of cocoa beans, although it works well with products like sand etc.</p>
 <p>What if I want to increase the output? Can I speed up the rope assembly?</p>	<p>No. If you change the speed, you interfere with the principle of operation. If you want more throughput, you may be able to change the hopper inlet. Generally, you increase or decrease the throughput by increasing or decreasing the flow of material into the machine, up to the limit it can handle. The speed of the FLOVEYOR remains unaltered.</p>



F2 Stainless Steel Accessories -

- Standard base
- B-type hopper
- 120 Discharge chute

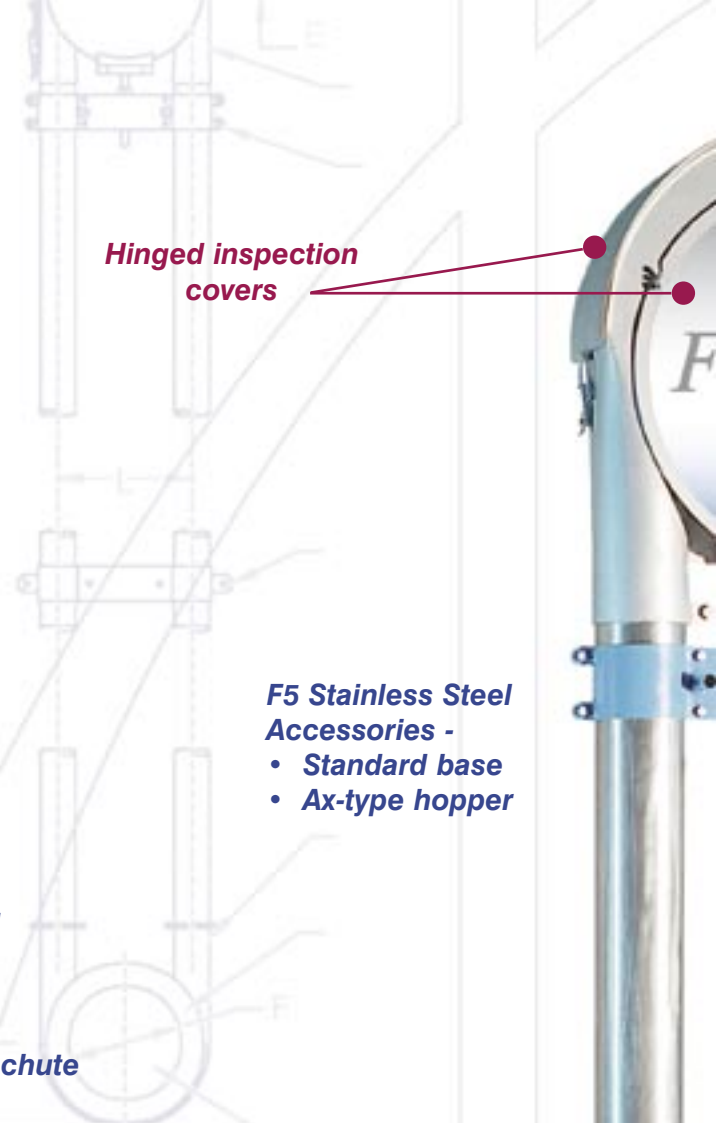

Hinged inspection covers

F5 Stainless Steel Accessories -

- Standard base
- Ax-type hopper

Flanged tubes & lower housing connections

Slimline Multi-position base design

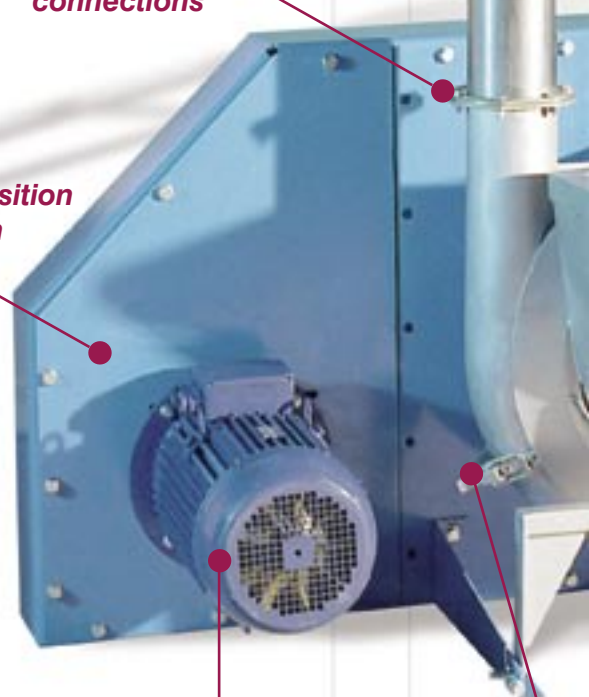

Drive assembly integrated with base

Quick release attaching



base clips for
inlet accessories

Quick angle
adjustment

Hinged hoppers with
quick removal



**F4 Mild Steel
Accessories -**

- Standard base
- A-type hopper
- 120 Discharge chute
- M1 Mobile attachment



**F3 Stainless Steel
Accessories -**

- Standard base
- 120 Discharge chute
- Standard Screwfeeder:
Accessories -
- Castors
- Bridge over screw
- Grid

INLET

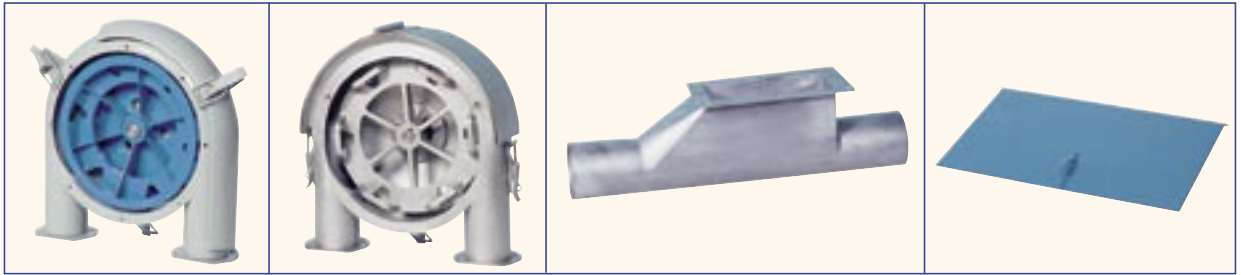

1. **PU reinforced feed housing**
F2 - F5
FLOVEYORs
2. **Sand Sprocket**
F3 - F5
FLOVEYORs

1. **Hinged feed housing**
F3 - F5 **FLOVEYORs**
2. **Undersized Sprocket**
F3 - F5 **FLOVEYORs**

Inlet
F3 - F5 **Drag units**

Hinged Lid
A & B-type **Hoppers**
All **Screwfeeders**

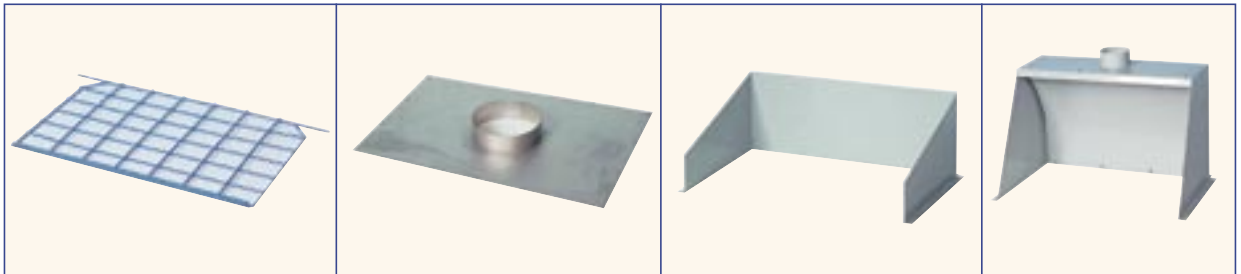

Grid
A & B-type **Hoppers**
All **Screwfeeders**

Adaptor Lid
All **Hopper types**
All **Screwfeeders**

Splash Guard
A & B-type **Hoppers**
All **Screwfeeders**

Dust Hood
B-type **Hoppers**
All **Screwfeeders**

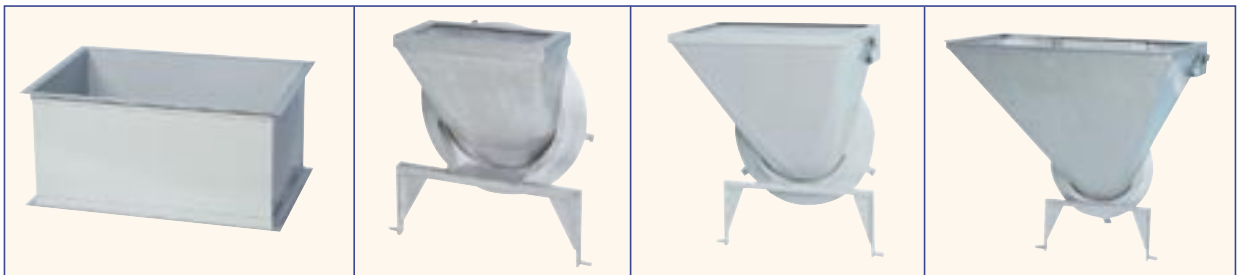

Hopper Extension
A & B-type **Hoppers**
All **Screwfeeders**

Ax Hopper (short A)
F3 - F5 **FLOVEYORs**

A-type Hopper
F3 - F5 **FLOVEYORs**

B-type Hopper
F2 - F5 **FLOVEYORs**

GENERAL

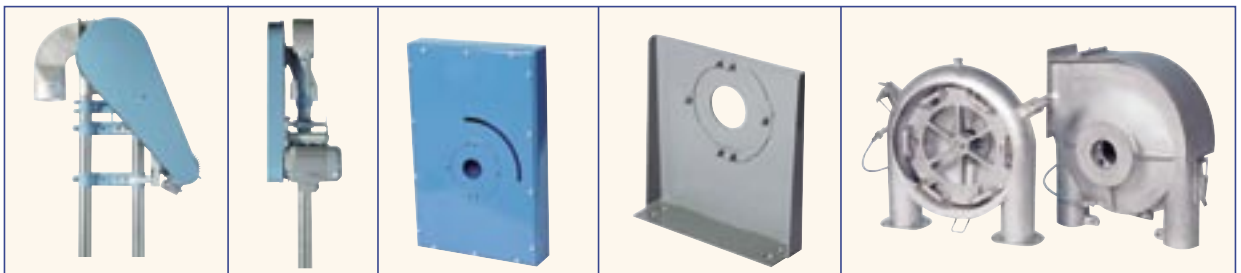

Top Drive
F3 - F5 **FLOVEYORs**

Simplified Base
for top drive
F3 - F5 **FLOVEYORs**

Mini Base
for top drive
F3 - F5
FLOVEYORs

Air Nozzles
Fitted to feed
& discharge
housings
F2 - F5 **FLOVEYORs**

DISCHARGE SPECIFICATIONS

	A	B	C	D	E	F	G	H
F2	0 or 20°	122	150	188	100	155	55	140
F3	0 or 20°	173	275	215	150	174	87	190
F4	0 or 20°	173	275	273	200	234	113	240
F5	0 or 20°	242	275	318	250	285	138	290

	J	K	M	N	P	Q	R	S
F2	50	51	127	127	152	180	150	500
F3	75	76	178	183	210	230	300	500
F4	75	101	178	183	210	230	300	500
F5	75	127	247	252	277	297	300	700

Accessories not shown:
 Flanged tube joiners
 Washing insert
 Drain plug in mild steel lower housing
 Pinned hinged top cover
 Fixed baffle
 Sliding baffle
 Sugar baffle
 Pneumatic sliding baffle
 Earthing lugs
 Transfer equipment
 Stainless steel shields on undersize discs
 Undersize discs on rope assembly

DISCHARGE

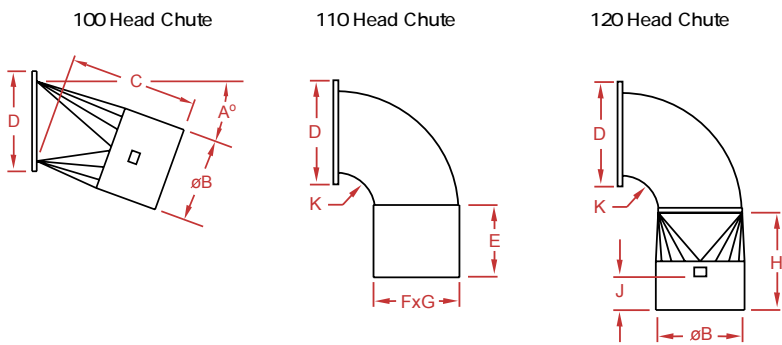

DISCHARGE ANGLE

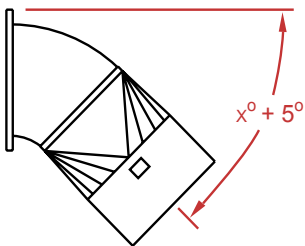

110 & 120 Head Chutes must be cut to suit correct discharge angle

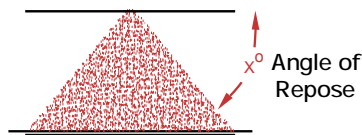

Please Note: Discharge angle must exceed angle of repose of material

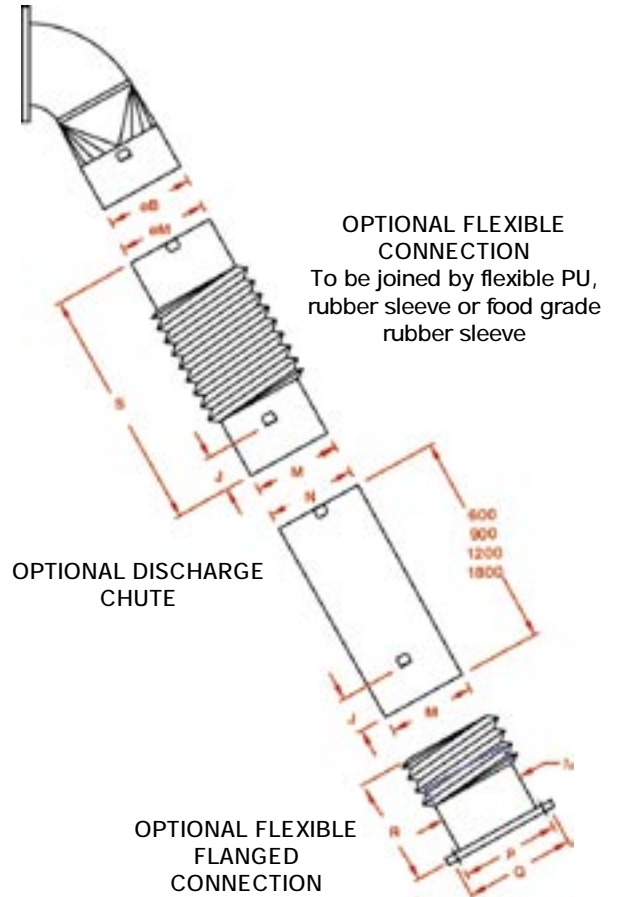

2-way discharge
 Optional Pneumatic control
 F2 - F5 FLOVEYORs

3-way discharge
 Standard pneumatic control
 F2 - F5 FLOVEYORs

Drop-Out
 Pneumatic control
 F3 - F5 Drag Units

Screw feeders

Mini

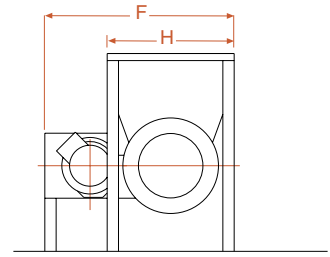
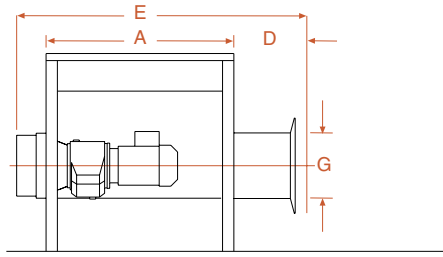

Standard

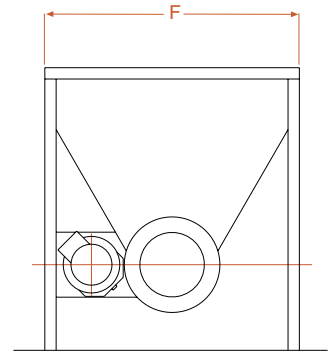
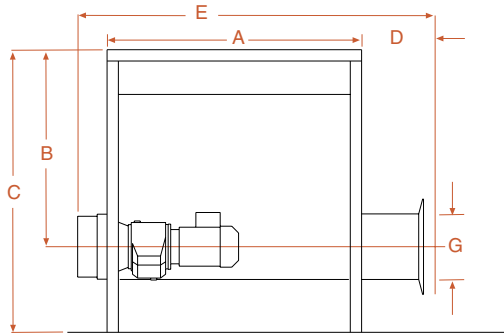

Drop Out

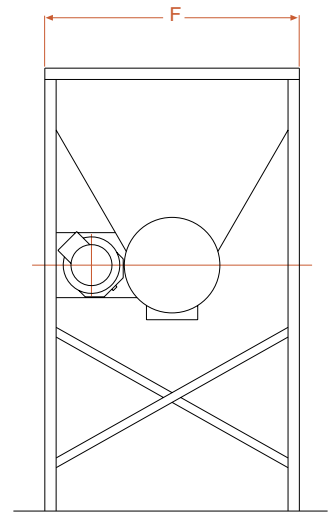
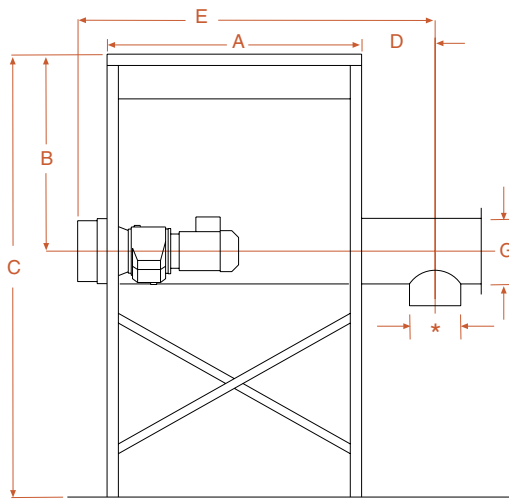

	A	B	C	D	E	F	ØG	H
Mini - F3	660	397	700	260	1026	667	232	445
Standard - F3	990	697	1000	260	1264	900	232	N/A
Dropout - F3	900	697	*	*	*	900	232	N/A
Standard - F4	900	633	1000	300	1303	900	296	N/A
Dropout - F4	900	633	*	*	*	900	296	N/A
Standard - F5	900	563	1000	400	1403	900	296	N/A
Dropout - F5	900	563	*	*	*	900	296	N/A

*** Customer specified dimensions**

Questionnaire for "FLOVEYOR" Aero Mechanical Conveyor

Company Name.....Ø
Address.....Ø
.....Ø
.....Ø
Contact Person.....Ø
Phone No.....Ø Facsimile No.....Ø
E-Mail address.....Ø

*Leave blank any section you wish your distributor to recommend.

1.0 Product Details

- 1.1 Product or chemical name.....Ø
- 1.2 Specific gravity or density.....Ø
- 1.3 Particle size and variation.....Ø
- 1.4 Moisture content (%).....Ø
- 1.5 Temperature range (°C).....Ø
- 1.6 Angle of repose (°).....Ø
- 1.7 Is product abrasive?.....Ø
- 1.8 Is product fragile?.....Ø
- 1.9 Will product "Bridge"?.....Ø
- 1.10 Required capacity (kgs / hour).....Ø

2.0 Installation Details

- 2.1 FLOVEYOR configuration (see diagrams overleaf, e.g. 2 or 1 + 9).....Ø
- 2.2 Dimensions (A,B,C etc.).....Ø
- 2.3 Method of feeding (i.e. bags, conveyor, etc.).....Ø
- 2.4 No. of inlets required.....Ø
- 2.5 No. of dropouts required.....Ø

(Sketch overleaf)

3.0 Construction

- 3.1 FLOVEYOR size (i.e. F4).....Ø
- 3.2 Mild steel or stainless steel.....Ø
- 3.3 Fixed or mobile unit.....Ø
- 3.4 Electrical supply (Volts and Hz).....Ø
- 3.5 Special motor requirement.....Ø
- 3.6 Type of discharge required.....Ø
- 3.7 Type of hopper required.....Ø
- 3.8 Hopper accessories required.....Ø
- 3.9 Type of screwfeeder required.....Ø
- 3.10 Screwfeeder accessories required.....Ø
- 3.11 Is 'bulk bag' support required?.....Ø
- 3.12 Special requirements.....Ø

4.0 Operation / Environment

- 4.1 Duty (Hrs/day, Start/stop etc.).....Ø
- 4.2 Wet environment or wash down required.....Ø
- 4.3 Explosive environment.....Ø
- 4.4 Is dust control required?.....Ø

Remarks.....Ø
.....Ø
.....Ø

Please use the area on the back to sketch your layout or special requirements.
Please remove and send to your local FLOVEYOR distributor.



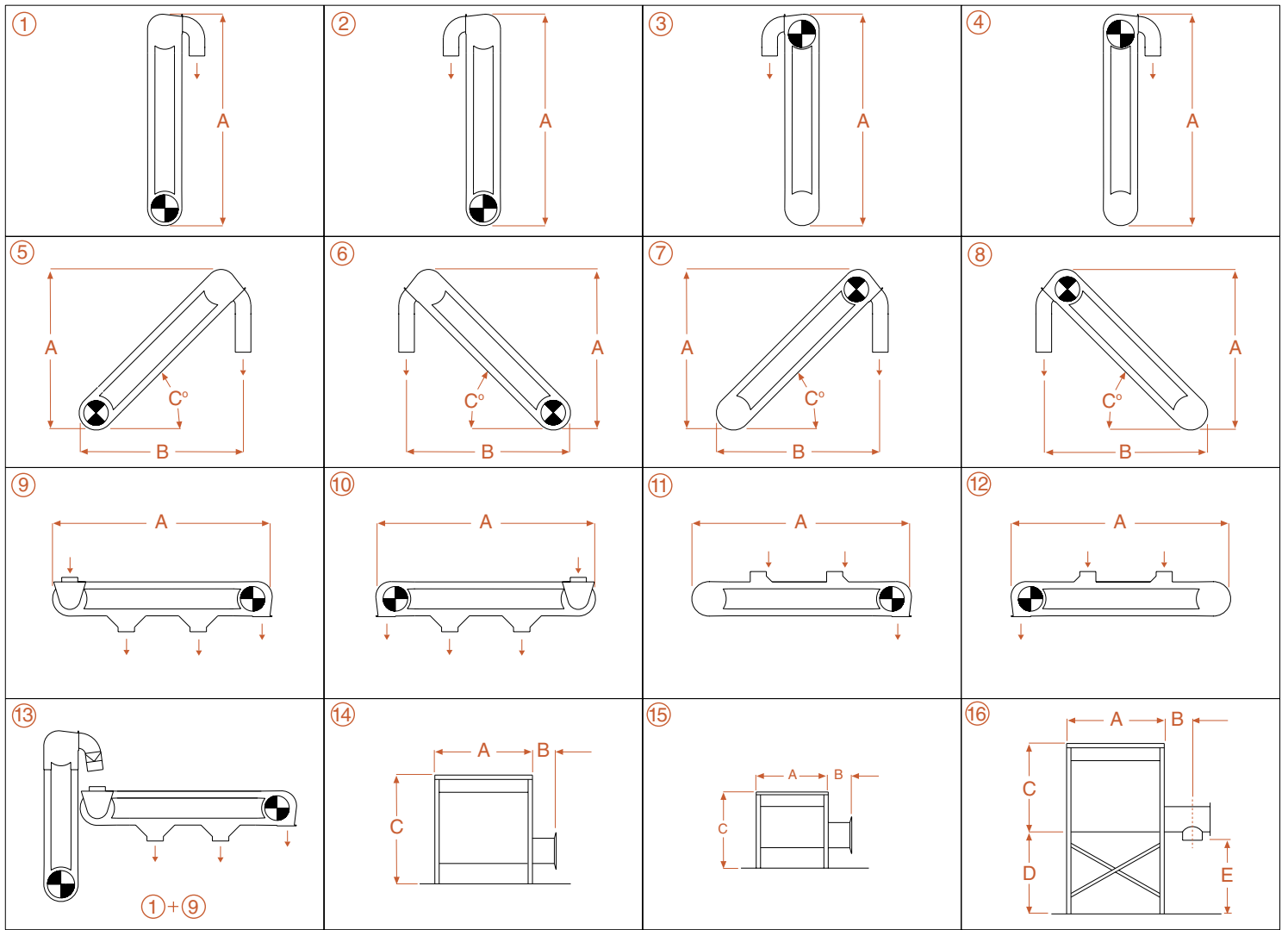

= Drive Position

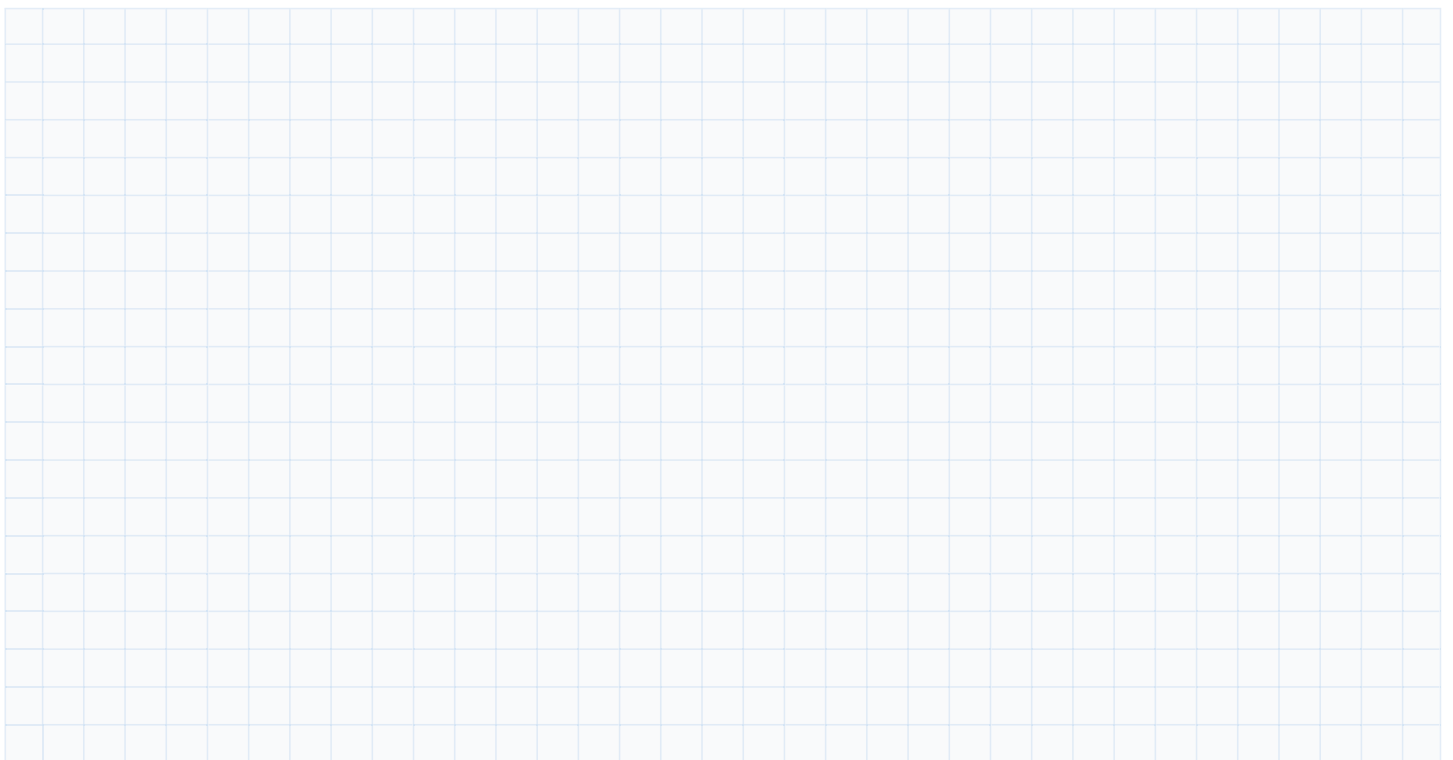

Dimensions

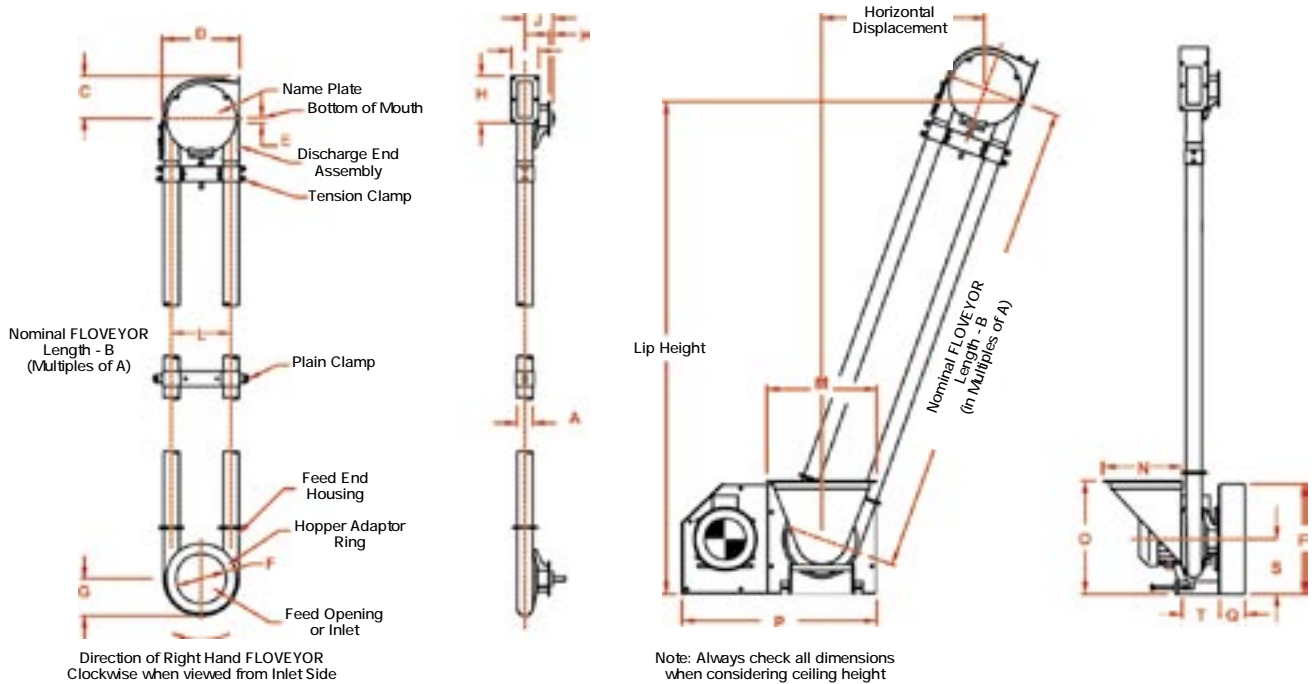

Table for Optional Hoppers *

	Hopper Type	Outside MxN	Inside MxN	O
F2	B	350 x 250	300 x 200	410
F3	Ax	356 x 203	306 x 153	487
	A	508 x 369	458 x 319	700
	B	660 x 445	610 x 395	700
F4	Ax	356 x 203	306 x 153	570
	A	508 x 369	458 x 319	700
	B	660 x 445	610 x 395	700
F5	Ax	450 x 245	370 x 165	697
	A	640 x 440	560 x 360	870
	B	830 x 530	750 x 450	870

All FLOVEYORs and accessories are available in either mild steel or 316 stainless steel construction. Your FLOVEYOR distributor will assist you to select the best construction type to suit product and environment.

FLOVEYOR Dimensions

	F2	F3	F4	F5
A	51	76	102	127
B Max. Std FLOVEYOR Horizontal & Vertical	5000	12000	15000	15000
B Max. Drag Unit	N/A	50000	50000	50000
C	172	216	283	358
D	320	386	514	641
E	3	22	25	48
∅ F	232	232	296	372
G	156	190	254	318
H	188	215	273	318
I	90	125	150	178
J	102	122	176	235
K	16	16	16	16
L	262	298	400	502
P	762	1057	1137	1266
Q	111	112	118	155
R	450	694	701	845
S	225	303	367	437
T	125	163	237	313

(All specifications subject to change without notice).

* All dimensions shown in millimetres

FLOVEYOR PTY LTD
6 Alice Street Bayswater Western Australia 6053
PO Box 116 Bayswater Western Australia 6933
Telephone: + 61 8 9378 3333 Facsimile: + 61 8 9378 3839
Email: sales@floveyor.com
www.floveyor.com

Your Authorised Distributors

FloAero Inc
PO Box 260563
Encino CA 91426-0563
Tel: 818/789-0546
Fax: 818/789-0593

Email: info@fbaero.com

